

Diagram 1

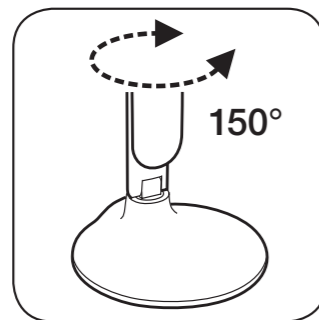

Diagram 2

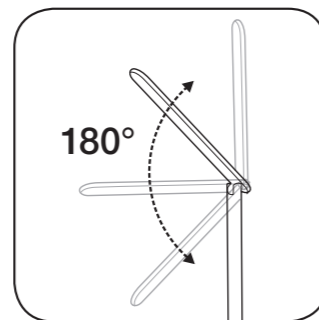

Diagram 3

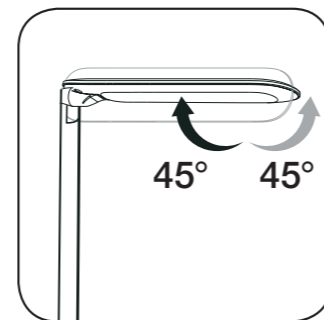

Diagram 4

CONGRATULATIONS!

You've purchased the finest in natural lighting technology with your new OttLite® product.

WARNING: To prevent electric shock, make sure the lamp is not plugged in until all steps are complete.

PRODUCT REGISTRATION FORM

Please complete the enclosed Product Registration Form and return it today by mail, or register online by going to: OttLite.com/warranty

NOTE: THIS UNIT IS FULLY ASSEMBLED

1. Remove lamp from packing, placing lamp body base (A) flat on a steady surface.
2. Connect power adapter input (F) into connector (G) in the rear-bottom of the lamp.
3. Plug the power adapter (H) into a standard household 120V AC outlet. **Note: Only use with the supplied power adapter to avoid damage or fire.**
4. Turn the lamp ON/OFF by using power switch (B) located on top of base (A).
5. Touch panel (B) includes multiple "touch" keys that control the lamp's light color mode and brightness within each color mode. This lamp provides five levels of brightness. See *Touch Key Instructions* section for operating instructions.
6. To reposition the light, hold the lamp base (A) steady and grasp either lamp body (C) or shade (D) depending on needed adjustment.
7. Refer to diagrams 1,2,3,4 for lamp maximum adjustment range. **NOTE: DO NOT FORCE** the shade or lamp body outside indicated adjustable range as excessive adjustment may cause damage.

TOUCH KEY PANEL INSTRUCTIONS:

To power lamp and operate LED settings, slightly touch required "key" to achieve the following:

- Turn lamp "ON/OFF": touch "POWER" key (B) as needed.
- To adjust brightness: touch "UP" key (K) or "DOWN" key (L) as needed.
- To adjust lighting color mode: touch "M" key (M) to switch light color mode; 2700K°, 4000K°, 5000K°.

GOOGLE HOME LAMP VOICE ACTIVATION INSTRUCTIONS:

NOTE 1: The Google Home Lamp Voice Activation feature will only operate on a 2.4GHz wireless network.

NOTE 2: If you already have Google Home set up, the prompts you will receive may vary from the details below.

1. Plug both the lamp and the Google Home device into an electrical outlet.
2. Download the free Google Home app from your app store on your mobile phone or tablet. Once the app has downloaded, 'open' the app.
 - Follow the prompts for "getting started" at the bottom of the screen on your mobile phone or tablet.
 - You will need to create an account and password to use this app. Follow the app's prompts to create an account.
 - Once the account is created, the app will need to verify your information by sending a verification code to your email account.
 - Enter in the verification code from your email into the app.
 - Agree to the terms.
 - Now the Google Home app starts 'Looking for Devices'
 - Press the "next" button and 'Google Home' will connect to the device.
 - You should hear a sound from the device indicating that you are now connected.
 - Choose a location for this device.
 - Choose your Wi-Fi network.
 - Link to your Wi-Fi network by entering in your network password.
 - Depress 'next' or you can 'learn more' when prompted "Before using your Google Assistant".
 - Follow prompts to set up voice match.
 - Enter in your address.
 - 'Almost done!' prompt depress "next".
 - You should now have a "Google Home is ready" message, depress 'continue'.
 - The Google Home device should now speak to you.
 - Continue past the next couple of screens
 - "Welcome Home" screen - you can browse here if you like.
 - Agree to the terms.
 - Turn on the settings.
 - Then repeat the messages on the screen and the Google Home device will now recognize your voice – depress 'continue'.

- Once completed you need to add devices, but before you can do this you must first download and register the Smart Life App.

3. Download the free Smart Life – Smart Living app from your app store on your mobile phone or tablet. Once the app has downloaded 'open' the app.
 - Follow the prompts for "registering".
 - You will need to enter in your mobile phone number and a verification code will be texted to you and create a password to use this app. Follow the app's prompts to complete this.
 - Depress the 'Devices' button at the bottom left of the screen.
 - To add a device, depress the '+' symbol in the upper right hand corner of your mobile phone or tablet screen.
 - Depress "Lighting devices", a flashing light bulb icon will appear on your mobile phone or tablet screen.
 - Depress and hold the "on/off" button on the actual lamp for 5 seconds to pair. The lamp should now be RAPIDLY blinking fast, if not follow the directions on how to make the actual lamp blink fast– see directions on your mobile phone or screen.
 - If the lamp is RAPIDLY blinking, depress "confirm light blinks rapidly" button on your mobile phone or tablet.
 - You will now need to link it to Wi-Fi -- follow the directions, enter in the Wi-Fi password, depress the 'confirm' button on your mobile phone or tablet.
 - You should now see "Successfully Added 1 Device" on the screen. The lamp will be listed.
 - Depress the edit icon and name your device/lamp.
 - Depress 'done'

4. Open the Google Home app to add the lamp you just setup in the Smart Life app.

- Go to the home page.
- Depress "Home Control" on menu screen.
- Depress "Devices".
- Depress "+" in bottom right hand corner of the screen to add a device.
- Scroll down and locate the "Smart Life" app and depress the icon.
- Enter in your phone number/email address and password.
- Depress "Authorize".
- The lamp should be listed under "Assign Rooms" assigning a room - assign a room for the lamp.
- Assign a nickname to the lamp.
- Depress "done".
- You can now use the voice activation feature to control the lamp.

NOTE: if at any point the lamp seems to stop following commands or malfunctions, simply turn the lamp off, wait 5 seconds and turn back on. The lamp will be reset.

5. Verbal Command Suggestions:

- "Hey Google, turn on the 'name you gave the lamp' light"
- "Hey Google, turn off the 'name you gave the lamp' light"
- "Hey Google, turn the 'name you gave the lamp' brightness 10%"
- "Hey Google, turn the 'name you gave the lamp' brightness to 80%"
- "Hey Google, turn the 'name you gave the lamp' brightness to 100%"

If you have more than one lamp assigned to a room, you can turn on and off the lamps at the same time:

- "Hey Google, turn on the 'room you assigned the lamps to i.e., family room, kitchen' lights".

If the lamp has multiple color temperatures:

- "Hey Google, turn the 'name you gave the lamp' to 'cool white'."
- "Hey Google, turn the 'name you gave the lamp' to 'bright white'."
- "Hey Google, turn the 'name you gave the lamp' to 'warm white'."

SAFETY WARNING: TO REDUCE THE RISK OF FIRE, ELECTRIC SHOCK, OR INJURY TO PERSONS

1. Turn lamp off and **WAIT UNTIL LAMP HEAD (D) IS COOL** before handling.
2. The LED panel (E) might get hot after several hours of continuous use **DO NOT** place your hands directly on LED light panel.
3. Never use with an extension cord unless the plug can be fully inserted into the receptacles in the extension cord.
4. Do not alter the plug.
5. The lamp head included with this unit cannot be replaced by the consumer.
6. INDOOR USE ONLY.

Command LED Desk Lamp with Voice Assistant

CS59029 CS59029-SHPR

T11FS

NOTE: The important safety instructions appearing in this instruction sheet are not meant to cover all possible conditions and situations that may occur. It must be understood that common sense, caution, and care must be used with any electrical product.

CAUTION! DEVICE MAY BECOME WARM DURING CHARGING. THIS IS NORMAL AND PART OF THE PROCESS. CHARGING TIMES VARY BY DEVICE.

CAUTION! IF THE EXTERNAL FLEXIBLE CABLE OR CORD OF THIS LUMINAIRE IS DAMAGED, IT SHALL BE EXCLUSIVELY REPLACED BY THE MANUFACTURER OR ITS SERVICE AGENT OR A SIMILAR QUALIFIED PERSON IN ORDER TO AVOID A HAZARD. INDOOR USE ONLY.

CAUTION! THE LIGHT SOURCE OF THIS LUMINAIRE IS NOT REPLACEABLE; WHEN THE LIGHT SOURCE REACHES ITS END OF LIFE THE WHOLE LUMINAIRE SHALL BE REPLACED.

FCC PART 15

Note: This equipment has been tested and found to comply with the limits for a Class B digital device, pursuant to Part 15 of the FCC rules. These limits are designed to provide reasonable protection against harmful interference in a residential installation. This equipment generates, uses and can radiate radio frequency energy and, if not installed and used in accordance with the instructions, may cause harmful interference to radio communications. However, there is no guarantee that the interference will not occur in a particular installation. If this equipment does cause harmful interference to radio or television reception, which can be determined by turning the equipment off and on, the user is encouraged to try to correct the interference by one or more of the following measures:

- Reorient or relocate the receiving antenna.
- Increase the separation between the equipment and receiver.
- Connect the equipment into an outlet on a circuit different from that of the receiver.
- Consult the dealer or an experienced radio/TV technician for help.

Changes or modifications not expressly approved by the party responsible for compliance could void the user's authority to operate the equipment.

This device complies with Part 15 of the FCC Rules. Operation is subject to the following two conditions:

- (1) this device may not cause harmful interference, and
- (2) this device must accept any interference received, including interference that may cause undesired operation.

CAN ICES-005 (B)/NMB-005 (B)

CAUTION: Any change or modification to product not expressly recognized by OttLite Technologies voids OttLite's responsibility for proper function of product.

POWER ADAPTER SPECIFICATION:

Input: AC 100-240V, 50/60 Hz, 0.8A

Output: 15V DC, 1.4A with a Male DC Plug

THIS LAMP CONTAINS a 5V, 2,1A USB output port (J) located on the bottom rear of lamp. USB port can charge items such as tablets, cellular phones, etc.

Google Home and Google Assistant are trademarks of Google, Inc.